

Sign

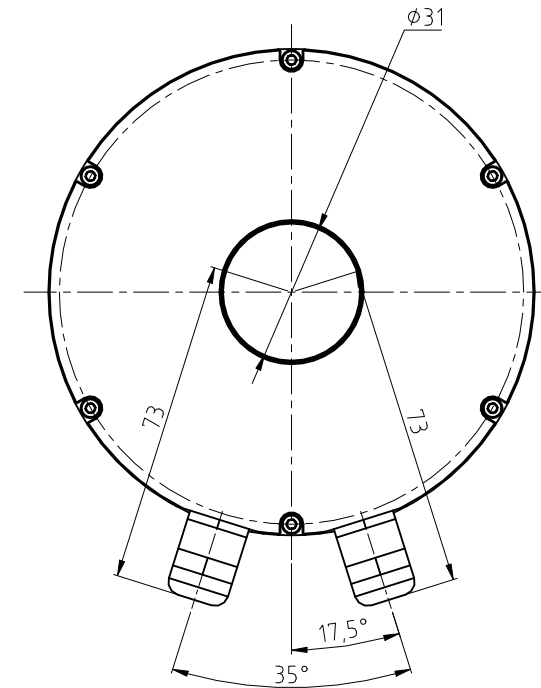
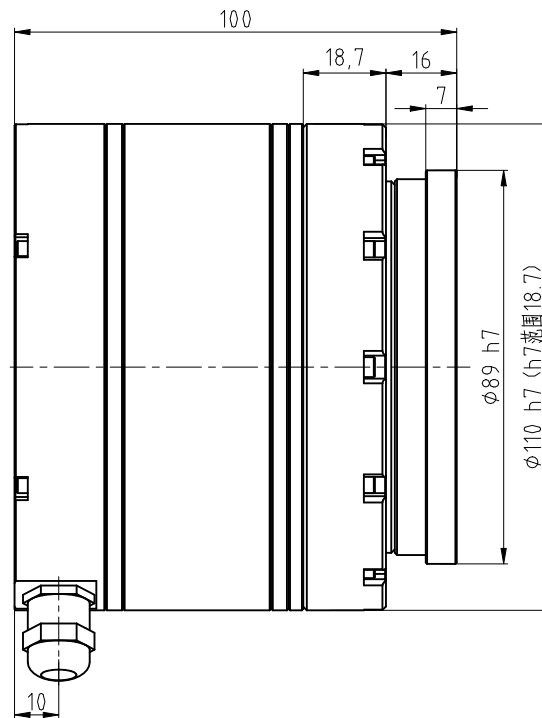
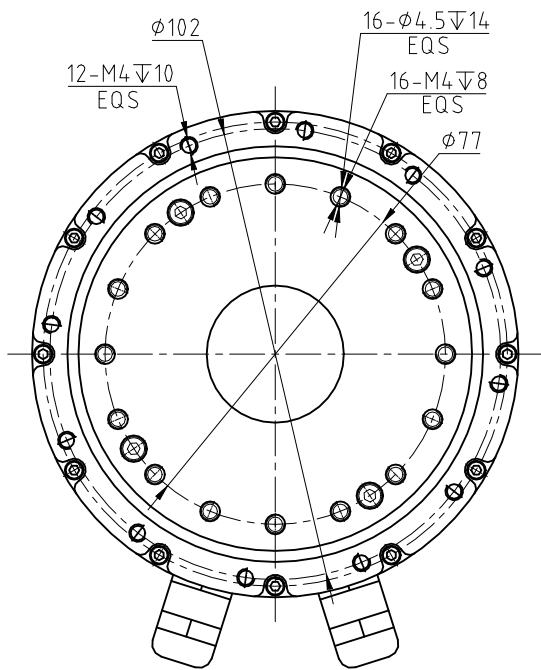

				Joint Module			M110-B-XXX-BS-C00	
							GJ-DW-ME-0082	
标记	处数	更改内容	签字	日期	客户图样标记	重量(kg)	比例	 Laitual Drive 浙江来福谐波传动股份有限公司
设计							1:1	
审核								
批准								
工艺会签								
		版本号	A5		共 2 页	第 1 页		

Motor Parameter	
Voltage	AC220V
Rated Power	600W
Rated Speed	3000rpm
Max Speed	5600rpm
Motor Phase Resistance	0.51 Ohms
Motor Phase Inductance	1.75mH
Back EMF	27.51V <sub>rms</sub> /krpm
Number of Pole Pairs	10

Sign

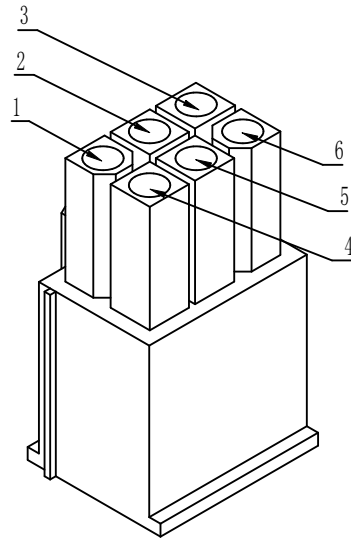

Power Connector:

Module-side connector housing: HX41405-6P  
 Module-side connector terminals: HX41406-6R / RT Customer-side connector housing: HX41406-6R  
 Customer-side connector terminals: HX41406-6P / PT

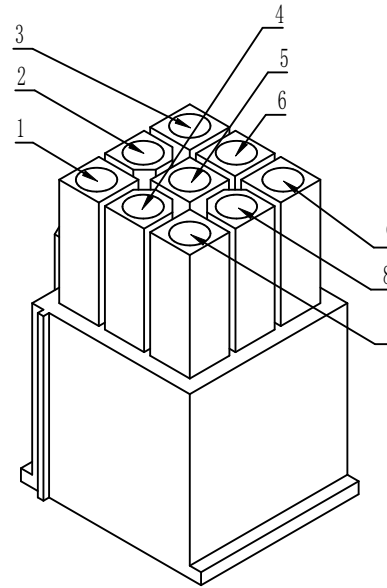

Encoder Connector:

Module-side connector housing: HX41405-9P  
 Module-side connector terminals: HX41406-9R / RT Customer-side connector housing: HX41406-9R  
 Customer-side connector terminals: HX41406-9P / PT

Housing 1: Power Connector		
Pin No.	Signal Name	Note
1	U	
2	V	
3	W	
4	GND	
5	Brake+	
6	Brake-	
Housing 2: Encoder Connector		
Pin No.	Signal Name	Note
1	SL1+	Communication+
2	GND	Ground
3	Vcc	Power
4	MA1+	Clock+
5	MA1-	Clock-
6	SL1-	Communication-
7	PG	Shielding
8	Battery-	
9	Battery +	

Technical Requirements:

- The module power cable and signal cable shall have a lead length of 300 mm each.
- Insulation resistance (DC 500V) 500 M $\Omega$ ; dielectric withstand voltage: AC 1500V for 1 minute.
- Encoder type: Absolute encoder; Encoder protocol: BiSS-C; Encoder resolution: 16-bit single-turn, 17-bit single-turn.
- The appearance shall be free from visible defects such as burrs, scratches, dents, or damage.
- Standard version:  
Storage temperature: -20°C to 80°C Operating temperature: -10°C to 55°C
- Special version:  
Storage temperature: -40°C to 80°C Operating temperature: -30°C to 55°C
- Protection class: IP66.
- Positioning accuracy (unidirectional): 60 arcsec; Repeatability: 20 arcsec.

Joint Module Parameter										Joint Module			M110-B-XXX-BS-C00							
Ratio	Per. Max Value for Ave. Load torque (Nm)	Permissible peak torque at start/stop (Nm)	Instantaneous Permissible max.torque(Nm)	Rated Speed (rpm)	Max Speed (rpm)	Rated Current (A)	Max Current (A)	Tq Constant (Nm/Arms)	Inertia Moment (kg $\cdot$ mm <sup>2</sup> )	Weight (kg)	标记处数	更改内容	签字	日期	客户图样标记	重量(kg)	比例			
51	72	127	242	58.8	109.8	4.62	8.15	15.58	286	2.91 (With brake)	设计				GJ-DW-ME-0082	1:1	<b>Laitual Drive</b> 浙江来福谐波传动股份有限公司			
81	113	178	332	37	69.1	4.57	7.19	24.74		审核										
101	140	204	369	29.7	55.4	4.54	6.61	30.85		批准										
121	140	217	395	24.8	46.3	3.79	5.87	36.96		2.83 (Without Brake)	工艺会签									
											版本号			A5			共 2 页		第 2 页	