

Sign

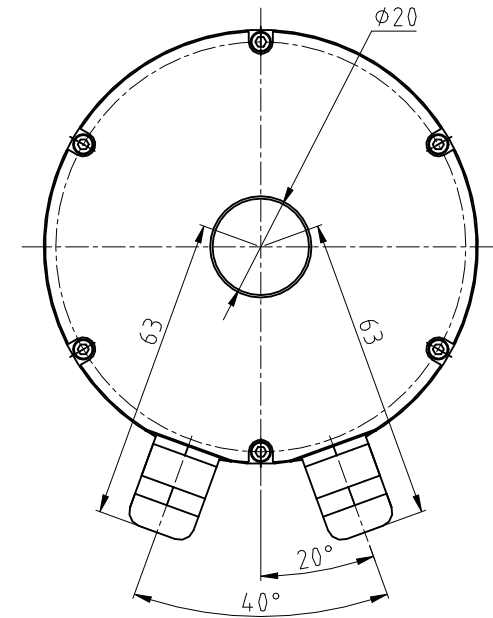
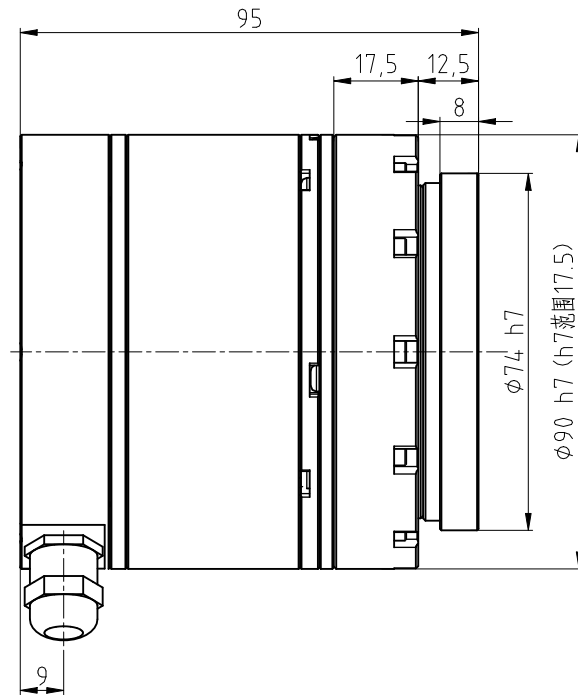
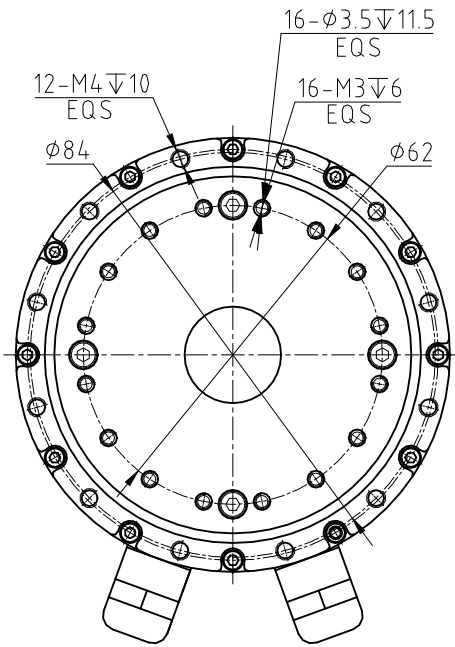

				Joint Module			M90-B-XXX-BS-C00	
标记	处数	更改内容	签字	日期	客户图样标记	重量(kg)	比例	 Laitual Drive 浙江来福谐波传动股份有限公司
设计							1:1	
审核								
批准								
工艺会签				版本号		A5		
				共 2 页		第 1 页		

Motor Parameters	
Voltage	AC220V
Rated Power	200W
Rated Speed	3000rpm
Max Speed	6000rpm
Motor Ph. Res.	3.06Ohm
Motor Ph.Ind.	6.4 mH
Motor Back EMF	30.72Vrms/krpm
Motor Pole Pairs	8

Sign

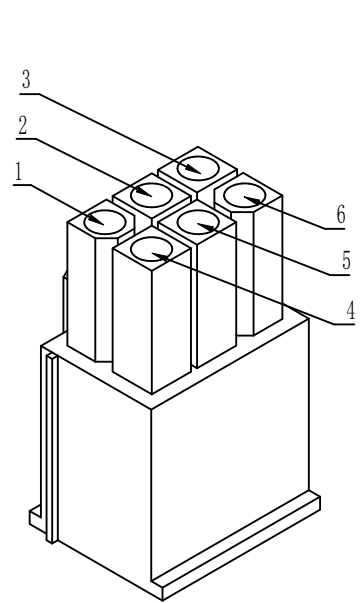

Power Connector:
 Module-side connector housing: HX41405-6P
 Module-side connector terminals: HX41406-6R / RT Customer-side connector housing: HX41406-6R
 Customer-side connector terminals: HX41406-6P / PT

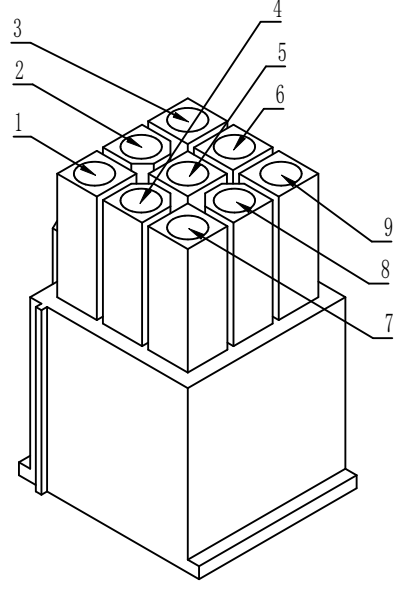

Encoder Connector:
 Module-side connector housing: HX41405-9P
 Module-side connector terminals: HX41406-9R / RT Customer-side connector housing: HX41406-9R
 Customer-side connector terminals: HX41406-9P / PT

- Technical Requirements:**
- The module power cable and signal cable shall have a lead length of 300 mm each.
 - Insulation resistance (DC 500V) 500 M ; dielectric withstand voltage: AC 1500V for 1 minute.
 - Encoder type: Absolute encoder; Encoder protocol: BiSS-C; Encoder resolution: 16-bit multi-turn, 17-bit single-turn.
 - The appearance shall be free from visible defects such as burrs, scratches, dents, or damage.
 - Standard version:
 Storage temperature: -20°C to 80°C Operating temperature: -10°C to 55°C
 - Special version:
 Storage temperature: -40°C to 80°C Operating temperature: -30°C to 55°C
 - Protection class: IP66.
 - Positioning accuracy (unidirectional): 60 arcsec; Repeatability: 20 arcsec.

Housing 1: Power Connector		
Pin No.	Signal Name	Note
1	U	
2	V	
3	W	
4	GND	
5	Brake+	
6	Brake-	

Housing 2: Encoder Connector		
Pin No.	Signal Name	Note
1	SL1+	Communication+
2	GND	Ground
3	Vcc	Power
4	MA1+	Clock+
5	MA1-	Clock-
6	SL1-	Communication-
7	PG	Shielding
8	Battery-	
9	Battery +	

Joint Module Parameter											Joint Module			M90-B-XXX-BS-C00						
Ratio	Per. Max Value for Ave. Load torque (Nm)	Permissible peak torque at start/stop (Nm)	Instantaneous Permissible max.torque(Nm)	Rated Speed (rpm)	Max Speed (rpm)	Rated Current (A)	Max Current (A)	Tq Constant (Nm/Arms)	Inertia Moment (kg•mm ²)	Weight (kg)				标记	处数	更改内容	签字	日期	客户图样标记	重量(kg)
51	44	73	127	58.8	117.6	3.11	5.17	14.13	108	1.96 (With brake)	设计					共 2 页	第 2 页	1:1	Lafual Drive 浙江来福谐波传动股份有限公司	
81	61	96	165	37	74.1	2.72	4.28	22.44			审核									
101	64	107	191	29.7	59.4	2.29	3.82	27.99			批准									
121	64	113	191	24.8	49.6	1.91	3.37	33.53			工艺会签									
											版本号 A5									